

R15

Code No: 125DY

JAWAHARLAL NEHRU TECHNOLOGICAL UNIVERSITY HYDERABAD

B. Tech III Year I Semester Examinations, May - 2018

DYNAMICS OF MACHINERY
(Common to AME, MSNT, ME, MCT)

Time: 3 hours

Max. Marks: 75

Note: This question paper contains two parts A and B.

Part A is compulsory which carries 25 marks. Answer all questions in Part A. Part B consists of 5 Units. Answer any one full question from each unit. Each question carries 10 marks and may have a, b, c as sub questions.

Illustrate your answers with NEAT sketches wherever necessary.

PART - A

(25 Marks)

- 1.a) State the D' Alembert's principle for Rectilinear motion, and Angular motion. [2]
- b) What do you understand by spin, precession and gyroscopic planes? Explain briefly. [3]
- c) What do you understand by 'self-locking brake' and 'self-energized brake'? [2]
- d) List the assumptions made in estimating the HP absorbed by friction in a footstep bearing. [3]
- e) What is the difference between the Porter and Proell governors? [2]
- f) What do you mean by 'Equivalent Inertia force'? [3]
- g) Explain the terms: Primary distributing force and Secondary distributing force. [2]
- h) What is meant by static and dynamic unbalance in machinery? How can the balancing be done? [3]
- i) What is torsionally equivalent shaft? [2]
- j) Explain briefly, with sketches the longitudinal, transverse and torsional free vibrations. [3]

PART - B

(50 Marks)

- 2.a) An aeroplane makes a half circle of 100 m radius towards when flying at 400 kmph. The engine and propeller of plane weigh 500 kg, and have a radius of gyration of 30 cm. The engine rotates at 3000 rpm *ccw*, when viewed from the front end. Find the gyroscopic couple.
- b) Derive the condition for the limiting value of the *Angle of heel (θ)* to avoid skidding of two-wheeled vehicle. [5+5]

OR

3. Refer to Figure 1.
- a) Determine the force acting perpendicular to link 2 and passing through its mid-point, for static equilibrium. What are the pin forces? Static equilibrium. What are the pin forces?
- b) Instead of a force on link 2, if link 2 is a driving crank, determine the couple C_2 necessary for static equilibrium. Determine also the pin forces. [5+5]

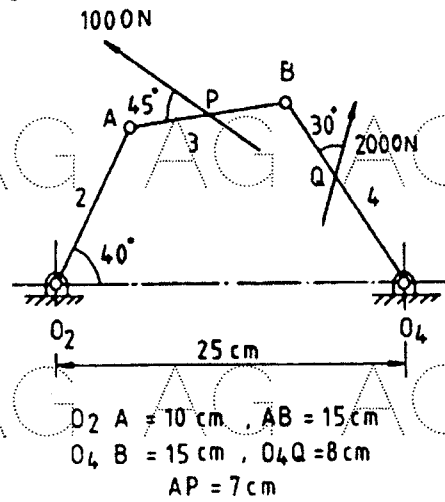

Figure 1

4. 100 kW is transmitted at 3000 rpm by a multiple disc friction clutch. The plates are having friction surface with a coefficient of friction 0.07, and the axial intensity of pressure is not to exceed 1.5 bar. External radius is 1.25 times the internal radius, and the external radius is 12.5 cm. Determine the number of plates needed to transmit the required torque. Assume uniform wear. [10]

OR

- 5.a) A torsion dynamometer is fitted on a turbine shaft to measure the angle of twist. It is observed that the shaft twists 2° in a length of 5 m at 600 rpm. The shaft is solid and has a diameter of 250 mm. If the modulus of rigidity is 84 GPa, find the power transmitted by the turbine.
- b) Which of the two assumptions, uniform intensity of pressure or uniform rate of wear, will you make use of in designing a friction clutch, and why? Give reason. [5+5]

6. In a turning moment diagram, the areas above and below the mean torque line, taken in order, are : 5.81, 3.23, 3.87, 5.16, 1.94, 3.87, 2.58, and 1.94 cm^2 respectively. The scales of the diagram are: Turning moment $\Rightarrow 1 \text{ cm} = 7 \text{ kN-m}$; Crank angle $\Rightarrow 1 \text{ cm} = 60^\circ$. The mean speed of the engine is 120 rpm, and the variation of speed must not exceed $\pm 3\%$ of the mean speed. Assuming the radius of gyration of the flywheel to be 106.67 cm, find the weight of the flywheel to keep the speed within the given limits. [10]

OR

- 7.a) Draw a neat sketch of Proell governor. Establish a relation among the various forces acting on the bent link.
- b) Determine the: (i) maximum speed (ii) minimum speed (iii) range of speed of a Watt governor of open arm type shown in Figure 2 in which the length of arm $AE = 400$ mm, and length $EF = 60$ mm, when the angle θ changes from 40° to 30° [5+5]

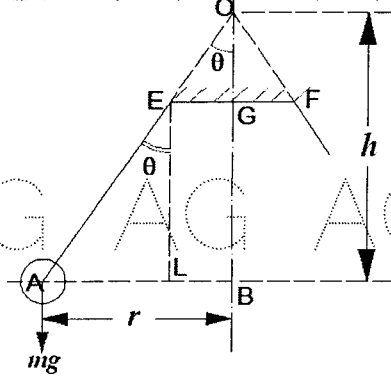

Figure 2

8. The following data refer to two cylinder locomotive with cranks at 90° : Reciprocating mass per cylinder = 300 kg ; Crank radius = 0.3 m ; Driving wheel diameter = 1.8 m ; Distance between cylinder centre lines = 0.65 m ; Distance between the driving wheel central planes = 1.55 m. Determine a) the fraction of the reciprocating masses to be balanced, if the hammer blow is not to exceed 46 kN at 96.5 kmph, b) the variation in tractive effort and c) the maximum swaying couple. [10]

OR

- 9.a) Explain the terms: variation of tractive force; swaying couple and hammer blow.
- b) Four masses M_1, M_2, M_3 and M_4 are 200 kg, 300 kg, 240 kg and 260 kg respectively. The corresponding radii of rotation are 0.2 m, 0.15 m, 0.25 m and 0.3 m respectively and the angle between successive masses are $45^\circ, 75^\circ$ and 135° . Find the position and magnitude of balance mass required if its radius of rotation is 0.25m. [5+5]

- 10.a) In the case of free torsional vibrations of two – rotor system, prove that the node divides the length of the shaft in the inverse ratio of the moments of inertia of the corresponding rotors.
- b) In a spring – mass vibrating system, the natural frequency of vibration is 3.56 Hz. When the amount of suspended mass is increased by 5 kg, the natural frequency is lowered to 2.9 Hz. Determine the original unknown mass and the spring constant. [5+5]

OR

- 11.a) Find the frequency of transverse vibrations of a shaft which is simply supported at the ends and is of 40 mm in diameter. The length of the shaft is 5 m. The shaft carries three point loads of masses 15 kg, 35 kg and 22.5 kg at 1 m, 2 m and 3.4 m respectively from the left support. The Young's modulus for the material of the shaft is 200 GN/m^2 . The weight of the shaft is 18.394 N per meter length.
- b) Describe, with relevant sketches, the Equilibrium method to find the natural frequency of free longitudinal vibrations. [5+5]