

Code No: 115DY

R13

JAWAHARLAL NEHRU TECHNOLOGICAL UNIVERSITY HYDERABAD

B. Tech III Year I Semester Examinations, November/December - 2016

DYNAMICS OF MACHINERY

(Common to AME, ME, MCT, MSNT)

Time: 3 hours

Max. Marks: 75

Note: This question paper contains two parts A and B.

Part A is compulsory which carries 25 marks. Answer all questions in Part A. Part B consists of 5 Units. Answer any one full question from each unit. Each question carries 10 marks and may have a, b, c as sub questions.

Illustrate your answers with NEAT sketches wherever necessary.

PART - A

(25 Marks)

1. a) What is the difference between applied and constrained forces? Explain. [2]
- b) With reference to Naval Ships, explain the terms: Bow, Stern, (or) Aft, Starboard, Port, Steering, Pitching, and Rolling. [3]
- c) Define the following terms: Friction, Limiting force of friction, co-efficient of friction and angle of friction. [2]
- d) Though cone clutches provide high frictional torque, yet they have become obsolete - Why? [3]
- e) What is the difference between centrifugal governors and inertia governors? [2]
- f) In a diesel generating set, is it possible to use only a flywheel or a governor? Give your answer with justification. [3]
- g) Explain the term 'partial balancing of primary force'. [2]
- h) What do you understand by inside cylinder locomotives and outside cylinder locomotives? [3]
- i) What is a torsionally equivalent shaft? [2]
- j) Define the terms: Damping factor, Coefficient of damping, and Critical damping Coefficient. [3]

PART - B

(50 Marks)

2. A motor cycle along with the rider weighs 2 KN, the C.G. of the machine and rider combined being 60 cm above the ground, with the machine in vertical position. The M.I. of each road wheel is 1030 N/mm^2 , and the rolling diameter is 60 cm. The engine rotates at 6 times of the road wheels and in the same sense. The M.I. of rotating parts of the engine is 165 N/mm^2 . Determine the angle of heel necessary if the unit is speeding at 62.5 km/h round a curve of 30.4 m. [10]

OR

3. The connecting rod of a gas engine weighs 700 N, and has a radius of gyration of 400 mm about an axis through the C.G. The length of the rod between centers is 1 m and the C.G. is 350 mm from the crank pin center. If the crank is 250 mm long, and revolves at a uniform speed of 300 rpm, find the magnitude and direction of the inertia force on the rod, and of the corresponding torque on the crankshaft when the inclination of the crank to the IDC is 135° . [10]

4. With a neat sketch, describe the principle and working of an internal expanding shoe – brake. Derive the expression for the force exerted by the cam (a) on the leading shoe, (b) on the trailing shoe. [5+5]

OR

5. In a belt transmission dynamometer shown in the Figure, the diameters of the driving and driven pulleys are 0.36 m and 0.80 m respectively. The power transmitted from the driving to the driven shaft is 20 kW. The speed of the driving shaft is 500 rpm. If $l = 1.2$ m and $a = 400$ mm, determine the weight on the lever. [10]

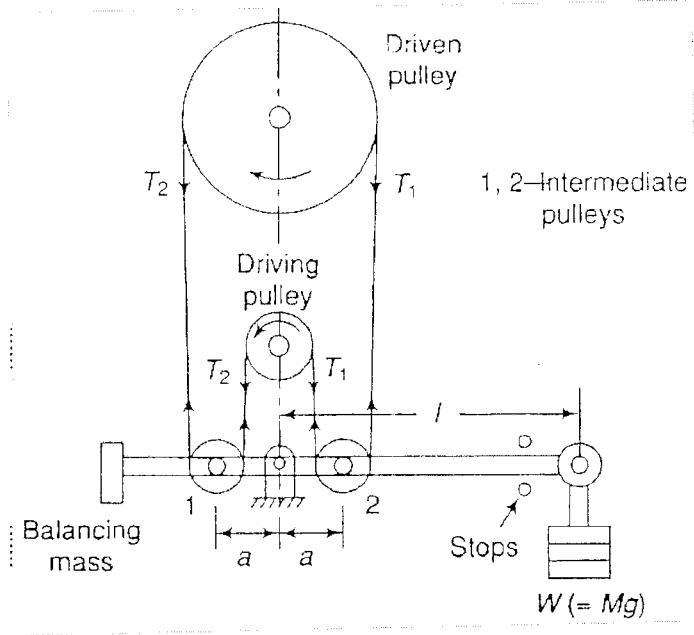

6. In a turning moment diagram, the areas above and below the mean torque line taken in order are 4400, 1150, 1300, and 4550 mm², respectively. The scales of the turning moment diagram are : Turning moment : 1 mm = 100 N – m ; Crank angle : 1 mm = 1°. Find the mass of the flywheel required to keep the speed between 297 and 303 rpm, if the radius of the gyration is 0.525 m. [10]

OR

7. Prove that for a Hartnell governor:

a) The total lift, $h = \frac{b}{a}(r_2 - r_1)$ and

b) Stiffness of spring, $s = \frac{a}{b} \left[\frac{S_2 - S_1}{r_2 - r_1} \right]$

where a and b = Lengths of bell – crank lever of ball – arm and sleeve – arm respectively, and S_2 and S_1 = Spring forces at maximum and minimum radii r_2 and r_1 respectively. [5+5]

8. If the balancing mass cannot be introduced in the same plane of rotation as that of the disturbing mass, then two balancing masses must be used. In such situation, explain the cases of (a) the planes of the balancing masses on the same side of the disturbing mass, and (b) the planes of the balancing masses on different sides of the disturbing mass. [5+5]

OR

9. A two-cylinder engine with cranks at 180° and the cylinders on the same side of the crankshaft center-line is having identical reciprocating masses, crank lengths and connecting rod lengths for each cylinder. If the crank of the first cylinder makes an angle of 30° with I.D.C., then to what extent the engine is balanced for:

a) Primary and secondary forces, and

b) Primary and secondary couples. [5+5]

10. Find the frequency of transverse vibrations of a shaft which is simply supported at the ends and is of 40 mm in diameter. The length of the shaft is 5 m. The shaft carries three point loads of masses 15 kg, 35 kg and 22.5 kg at 1 m, 2 m and 3.4 m respectively from the left support. The Young's modulus for the material of the shaft is 200 GN/m^2 . The weight of the shaft is 18.394 N per meter length. [10]

OR

11.a) In a spring-mass vibrating system, the natural frequency of vibration is 3.56 Hz. When the amount of suspended mass is increased by 5 kg, the natural frequency is reduced to 2.9 Hz. Determine the original unknown mass and the spring constant.

b) Explain how do you find the natural frequency of oscillation of a compound pendulum. [5+5]

---0000---