

Code No: 133BB

R16

JAWAHARLAL NEHRU TECHNOLOGICAL UNIVERSITY HYDERABAD

B.Tech II Year I Semester Examinations, November/December - 2018

KINEMATICS OF MACHINERY

(Common to ME, MSNT)

Time: 3 Hours

Max. Marks: 75

Note: This question paper contains two parts A and B.

Part A is compulsory which carries 25 marks. Answer all questions in Part A.

Part B consists of 5 Units. Answer any one full question from each unit.

Each question carries 10 marks and may have a, b, c as sub questions.

Illustrate your answers with NEAT sketches wherever necessary.

PART- A

(25 Marks)

- 1.a) What is *Gruebler's criterion* to find the degrees of freedom of a mechanism? Why is it sufficient to use the *Gruebler's criterion* instead of the *Kutzback's criterion* for plane mechanisms? [2]
- b) When does a kinematic chain become a: i) Structure, ii) Incompletely constrained and (iii) Redundant? Answer based on the relation between the number of links, and pairs. [3]
- c) What is '*Velocity image*' of a kinematic link? Explain with the necessary geometric construction. [2]
- d) Explain the three types of instantaneous centers for a mechanism. [3]
- e) Draw the sketch of a mechanism in which a point produces exact straight line motion. The mechanism must contain only revolute pairs. [2]
- f) Does the Ackermann steering gear mechanism satisfy the condition for correct steering for any angle of turn to the right or left? If not, why is it still preferred to the Davis steering gear mechanism? [3]
- g) What are the Cams with specified contours? Why are they necessary? Write their main advantage and limitation. [2]
- h) How do you determine the minimum width of the Flat-faced Follower? [3]
- i) Define (i) '*Law of Gearing*' and (ii) '*Velocity of Sliding*'. [2]
- j) In a reverted gear train, if the number of teeth of all the gear wheels except one wheel is known, how do you find the unknown value of gear teeth? [3]

PART-B

(50 Marks)

- 2.a) Distinguish between the *Drag-Crank mechanism* and *Double-crank mechanism*, with neat sketches. [5+5]
- b) In a *Crank-and-Slotted lever Quick-Return motion mechanism*, derive an expression for the ratio of the time of cutting stroke to the time of cutting stroke. [5+5]

OR

- 3.a) Describe, with a neat sketch, the rotary engine mechanism as an inversion of single slider crank chain. [5+5]
- b) In a crank and slotted lever mechanism, the driving crank is 35 mm long, and the time ratio of cutting stroke to return stroke is 1.6. If the length of working stroke of the ram is 110 mm, find the distance between the fixed centers, and the slotted lever length. [5+5]

- 4.a) Draw and explain the KLEIN's construction for the velocity diagram of a Reciprocating Engine Mechanism? With this construction, how do you find the velocities of the piston and connecting rod in terms of the uniform angular velocity of the crank?
- b) In a four-bar mechanism ABCD, AD is the fixed link, AB is the driving link and CD is the driven link. Show that the angular velocity of CD is to that of AB as QA is to QD, where Q is the point of intersection of BC and AD produced if necessary. [5+5]

OR

5. In the slider-crank mechanism shown in Figure 1, the block P reciprocates along the fixed line CD. The crank OA rotates *clockwise* at a uniform speed of 150 rpm. The dimensions of the links (in mm) are: OA=AB = 250; AP = 400; For the given configuration, find the velocity and acceleration of the block P. [10]

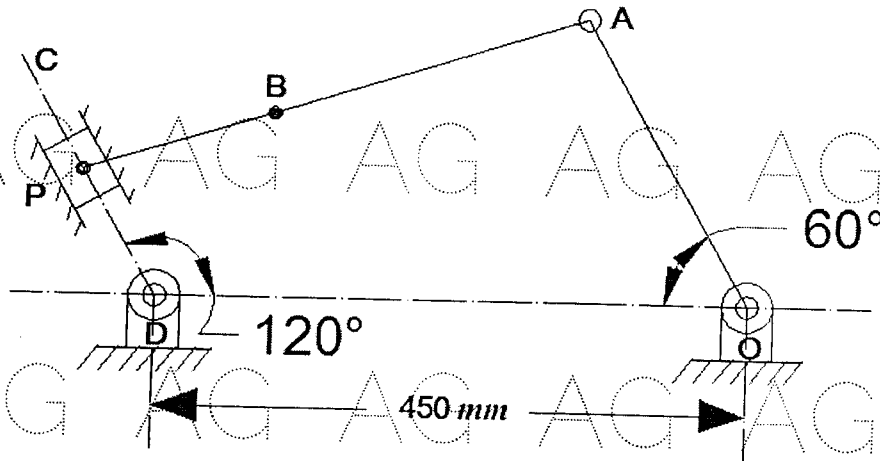

Figure: 1

- 6.a) Determine the greatest permissible angle between the axes of the two shafts which are connected by a Hooke's joint if the maximum variation in the speed of the driven shaft is  $\pm 6\%$  of the mean speed. The driving shaft is rotating at a uniform speed of 500 rpm.
- b) Show that in Watt's straight line motion mechanism, the tracing point P on the coupler divides it in the ratio of the length of the oscillating links which are connected by it. [5+5]

OR

- 7.a) Figure 2a, shows the Ackermann steering gear in neutral position, and the Figure 2b shows the steering gear when the vehicle turns to the right. A table is also given with the values of  $\theta$ ,  $\phi$ , and  $\phi_c$  where  $\phi_c$  is the correct value of  $\phi$  required to satisfy the condition for correct steering. Write your inferences from the table.

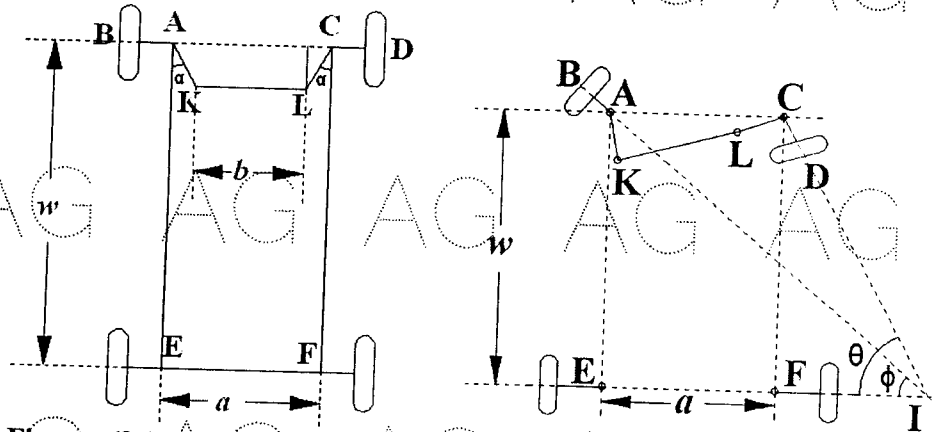

Figure: (2a)

Figure: (2b)

$\theta$	$10^\circ$	$20^\circ$	$30^\circ$	$40^\circ$	$50^\circ$
$\phi$	$9^\circ 25'$	$17^\circ 43'$	$24^\circ 40'$	$30^\circ 34'$	$34^\circ 43'$
$\cot \phi - \cot \theta$	0.356	0.383	0.431	0.501	0.604
$\phi_c$	$9^\circ 21'$	$17^\circ 38'$	$25^\circ 08'$	$32^\circ 08'$	$38^\circ 54'$

- b) Explain, through a Polar velocity diagram of Hook's Joint, the variation in the speed of the driven shaft with change in the speed of driving shaft and mark the salient features on the diagram. [5+5]

8. Draw the profile of a cam to give the following motion to a flat-faced follower:
- Follower to rise through 36 mm during  $120^\circ$  of cam rotation with uniform velocity
  - Follower to dwell for  $50^\circ$  of cam rotation
  - Follower to return to its initial position during  $90^\circ$  of cam rotation with SHM
  - Follower to dwell for the remaining period of cam rotation
- The minimum radius of cam is 50 mm. Also find the minimum width of the Follower from the cam profile diagram. [10]

OR

9. The follower of a tangent cam is operated through a roller of 50 mm diameter, and its line of stroke intersects the axis of the cam. Minimum radius of the cam is 40 mm, nose radius is 12 mm, and the lift is 25 mm. If the speed of rotation of the cam is 800 rpm, find the velocity and acceleration of the follower at the instant when the cam is  $25^\circ$  from the full-lift position. [10]

- 10.a) Two involute gears of  $20^\circ$  pressure angle have 25 teeth each. They are required to have an arc of contact which exceeds the circular pitch by 60%. Calculate the addendum of the gears.
- b) A simple Epicyclic gear train is shown in the figure 3. Deduce, from fundamentals, the expression for velocity ratio of the gear train. [5+5]

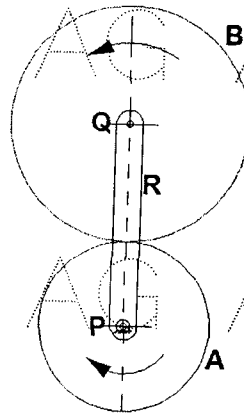

Figure: 3

OR

- 11.a) Deduce an expression for the velocity ratio of two mating helical gears in terms of their helix angles. Also prove that the VR is equal to  $\frac{T_1}{T_2}$ , where  $T_1$  and  $T_2$  are the number of teeth on the driver and follower wheels.

- b) The gearing of a machine tool is shown in Figure 4. The motor shaft is connected to the gear A, and rotates at 975 rpm. The gears B – C, and D – E are compound wheels fixed to parallel shafts, and rotate together. The final gear F is fixed on the output shaft 'G'. If the number of teeth on gears A, B, C, D, E, and F are 20, 50, 25, 75, 26, and 6 respectively, find the speed of the gear F. [5+5]

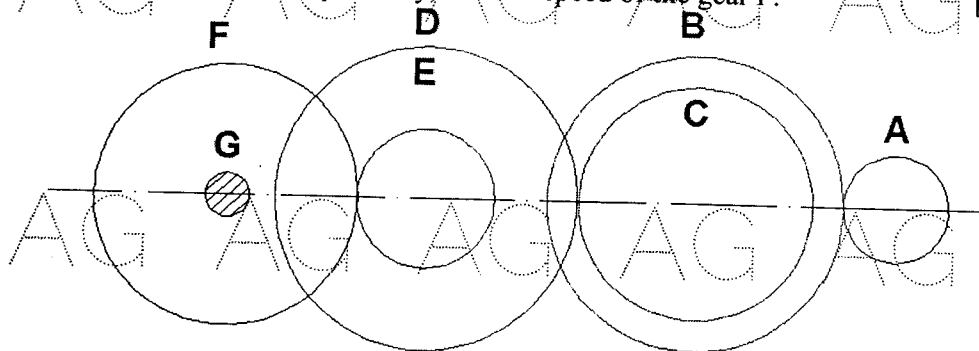

Figure: 4