

R16

Code No: 133BB

JAWAHARLAL NEHRU TECHNOLOGICAL UNIVERSITY HYDERABAD

B.Tech II Year I Semester Examinations, November/December - 2017

KINEMATICS OF MACHINERY

(Common to ME, MSNT)

Time: 3 Hours

Max. Marks: 75

Note: This question paper contains two parts A and B.

Part A is compulsory which carries 25 marks. Answer all questions in Part A.

Part B consists of 5 Units. Answer any one full question from each unit.

Each question carries 10 marks and may have a, b, c as sub questions.

Illustrate your answers with NEAT sketches wherever necessary.

PART- A

(25 Marks)

- 1.a) Distinguish between Rigid link, Flexible link, Fluid link, and Floating link. [2]
- b) In a kinematic chain having five links, the links are joined to each other by turning pairs in such a way as to form a pentagon. Show that it is an unconstrained chain. [3]
- c) If a link AB is rotating with uniform angular velocity, and the location of its instantaneous center of rotation is known, how do you find the velocity of any point on AB? Explain with the necessary geometric construction. [2]
- d) In a single slider crank chain ABC, A is the fixed point, AB is the crank rotating with uniform angular velocity  $\omega$ , BC is the connecting rod, and C is the slider. If a vertical drawn through 'A' intersects the line CB extended at 'D', then what are the velocities of the connecting rod and the slider? Give the answer by drawing a rough sketch of the mechanism. [3]
- e) Write the main advantage and the main limitation of the Hart mechanism over the Peaucellier mechanism. [2]
- f) Explain why two Hooke's joints are used to transmit motion from the engine to the differential of an automobile. [3]
- g) Write the expressions for the maximum velocity and maximum acceleration of the follower during its outstroke when the follower is moving with i) SHM ii) Uniform acceleration and retardation. [2]
- h) Write the basic differences between the tangent cam and a circular arc convex cam, both being operated by a roller follower. [3]
- i) Explain briefly the concept of Interference in gears. [2]
- j) Explain how you will determine the torques and the tooth loads in epicyclic gear train. [3]

PART-B

(50 Marks)

- 2.a) The distance between the axes of two parallel shafts of an Oldham coupling is 20 mm. The driving shaft rotates at 300 rpm. Calculate the maximum speed of sliding of the tongue of the intermediate piece along its groove.
- b) What are the different Inversions of a Double Slider crank chain? Describe the working of the inversion (with a neat sketch) which can be used to convert rotary motion to reciprocating motion. [5+5]

OR

- 3.a) Explain the different types of constraints between Kinematic pairs, and give two examples for each.
- b) A double slider mechanism is used to draw an ellipse with major axis equal to 20 cm and minor axis 15 cm. Set out the mechanism, and draw the locus of the points tracing the required ellipse. [5+5]
4. In a mechanism shown in Figure, the crank OA rotates clockwise at 200 rpm. The link lengths are: AB = 12 cm; BC = 48 cm; CD = 18 cm; DE = 36 cm; EF = 12 cm; FP = 36 cm. Find the velocities of the points C, E, and P, using the *Instantaneous center method*. (All dimensions are in cm). [10]

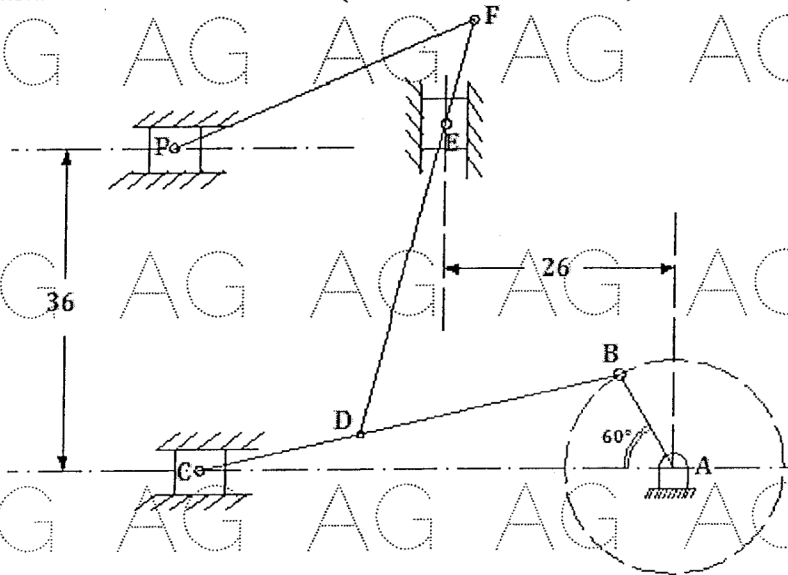

OR

5. If 'P' is a point on a link OR which is rotating about the fixed point 'O' with an angular velocity of  $\omega$ , and P is sliding *inwards* towards 'O' on the link OR with a linear velocity  $v$ , derive the expression for Coriolis component of acceleration when (a) both  $\omega$  and  $v$  are constant, b) both  $\omega$  and  $v$  vary with time. [10]
- 6.a) Draw a neat sketch of the *Robert's mechanism*, and explain its working. How do you find the location of the (tracing) point P which produces the approximate straight line motion?
- b) A Hooke's joint is used to connect two shafts. The driving shaft is rotating with a uniform speed of 600 rpm. The maximum speed of the driven shaft is 630 rpm. Find the minimum speed of the driven shaft. [5+5]
- OR
- 7.a) What condition is to be satisfied by the Davis steering gear whenever the vehicle is taking a turn - for any radius of curvature of the path of the vehicle? Derive the expression of this condition.
- b) Two shafts are connected by a Hooke's joint. The angle between the shafts is  $18^\circ$ . What will be the angle turned by the driving shaft when the velocity ratio is maximum? [5+5]

AG AG AG AG AG AG AG A

8. A symmetric circular cam with convex flanks operates a roller follower of radius 25 mm. Minimum radius of the cam is 60 mm, the radius of curvature of the flanks is 75 mm, and that of the rounded corner is 4 mm. Lift of the cam is 10 mm, and the angle through which the cam rotates from the beginning of the outstroke to the end of the instroke of the follower is  $120^\circ$ . If the cam rotates at a uniform speed of 1000 rpm, find (a) the maximum velocity of the follower, (b) the acceleration of the follower at the beginning and end of each stroke, (c) the acceleration at the instant the follower changes from contact with the flank to contact with the rounded corner of the cam profile. [10]

OR

9. Draw the profile of a cam to raise a valve with SHM through 40 mm in  $(1/4)^{th}$  of the cam rotation, keep it fully raised through  $(1/10)^{th}$  of the cam rotation, and to lower it with uniform and equal acceleration and retardation in  $(1/6)^{th}$  of the cam rotation. The valve remains closed during the rest of the cam rotation. The diameter of roller follower is 20 mm, and the minimum radius of cam is to be 30 mm. The axis of the follower passes through the axis of the cam shaft. [10]

10.a) Prove that the center distance between two involute gear teeth, which are in mesh, is given by  $C = \frac{(R_1 + R_2)}{\cos \phi}$ , where  $R_1$  = Radius of the base circle of wheel 1,  $R_2$  = Radius of the base circle of wheel 2 and  $\phi$  = Pressure angle.

b) The arm of an epicyclic gear train rotates at 100 rpm anti-clockwise. The arm carries two wheels A and B, having 36 and 45 teeth respectively, and meshing with each other. Wheel A makes 200 rpm clockwise, and the arm rotates about the center of wheel A. Find the speed of wheel B. [5+5]

OR

11.a) Two mating spur gears have 24 and 30 teeth, a standard addendum of one module, and a pressure angle of  $20^\circ$ . Find the length of the arc of contact in terms of the circular pitch.

b) Derive the expression for the velocity ratio of a compound gear train. [5+5]

---oo00o---

AG AG AG AG AG AG AG A

AG AG AG AG AG AG AG A

AG AG AG AG AG AG AG A