

**R15**

Code No: 124CZ

**JAWAHARLAL NEHRU TECHNOLOGICAL UNIVERSITY HYDERABAD**

**B.Tech II Year II Semester Examinations, May - 2017**

**KINEMATICS OF MACHINES**

**(Common to ME, MCT, MSNT)**

**Time: 3 Hours**

**Max. Marks: 75**

**Note:** This question paper contains two parts A and B.

Part A is compulsory which carries 25 marks. Answer all questions in Part A.

Part B consists of 5 Units. Answer any one full question from each unit.

Each question carries 10 marks and may have a, b, c as sub questions.

*Illustrate your answers with NEAT sketches wherever necessary*

**PART - A**

**(25 Marks)**

- 1.a) What is the difference between Mechanism, Machine, and Structure. [2]
- b) Explain the difference between Rigid Link, Flexible and Fluid link, with an example for each. [3]
- c) Define 'Instantaneous center of rotation' and state the Three-Centers-In-Line theorem. [2]
- d) Draw a rough sketch of Klein's construction for the velocity diagram of a Single slider crank mechanism and explain how you get the velocity of the slider. [3]
- e) What is the difference between the Scott-Russel and modified Scott - Russel mechanisms? Explain with sketches. [2]
- f) What is the main advantage of Double Hooke's joint over the Single Hooke's joint? [3]
- g) Name the different types of cams and followers. [2]
- h) What is the difference between the follower motion of uniform and equal acceleration and retardation and uniform and unequal acceleration and retardation. Explain with sketches of the relevant displacement diagrams. [3]
- i) What is the difference between compound gear train and reverted gear train? Explain with relevant sketches. [2]
- j) What is Interference in gears? When does it occur? [3]

**PART - B**

**(50 Marks)**

- 2.a) Explain, with a sketch, the drag-link mechanism.
- b) Draw the sketch of 'Ellipse Trammels', and prove how it can be used to draw an ellipse. [5+5]

**OR**

- 3.a) What is Kutzbach's criterion for degrees of freedom of plane mechanisms? In what way the Gruebler's criterion different from it?
- b) Draw the sketch of Whitworth quick return motion mechanism, and explain its working. [5+5]

4. The crank and connecting rod of a reciprocating engine are 30 cm and 150 cm long respectively. The crank rotates at 180 rpm clockwise. Determine the velocity and acceleration of the piston when the crank is at  $40^\circ$  from the IDC, Also determine the position of the crank for zero acceleration of the piston. [10]

OR

5. In the mechanism shown in figure 1, the driving crank OC rotates *ccw* about the fixed point O at a uniform speed of 150 rpm. The lever BD is pivoted about the pin D which is fixed and oscillates about D, A coupler BC connects the points B and C, The die block F, driven by the link EF moves in the horizontal guides. When the crank angle is  $45^\circ$ , find the velocity of F, using the *Instantaneous center method*. OC=DE=15 mm, CB=BD=45 mm, EF=25 mm. [10]

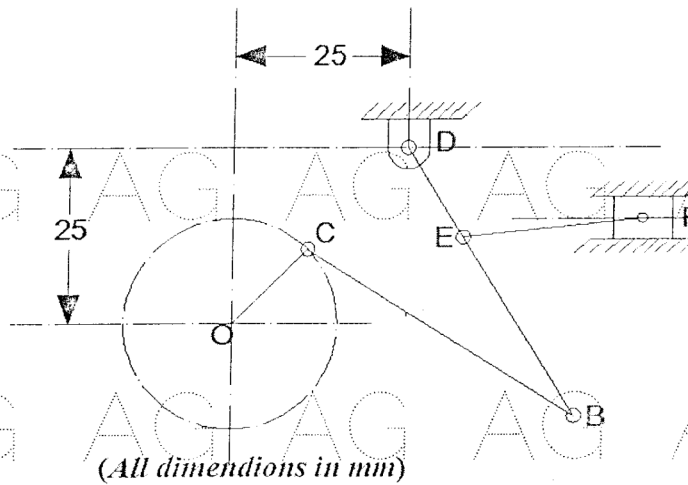

Figure: 1

6. In a Grass-Hopper mechanism shown in figure 2, the link lengths are: OQ = 100 mm, SP = 375 mm, QS = 150 mm, and SR = 225 mm. Find the magnitude of the vertical force necessary at P to resist a torque of 120 N-m applied to the link OQ when it makes an angle of  $15^\circ$  with the horizontal. [10]

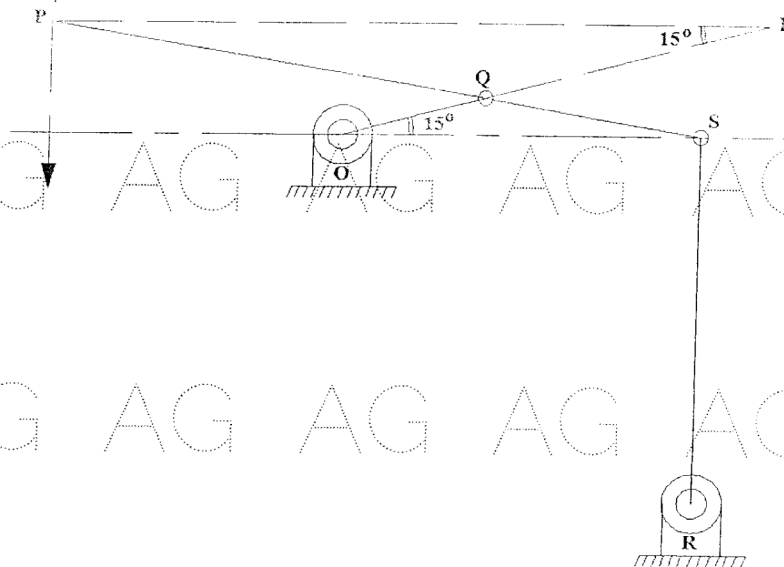

Figure: 2  
OR

- 7.a) Sketch the Hart mechanism, and prove that it produces an exact straight line motion.
- b) In a Hooke's joint, the angle between the axes of driving and driven shafts is  $15^\circ$ . Find the angle turned by the driving shaft when the velocity of the driven shaft is maximum, minimum, and is equal to that of the driving shaft. [5+5]

8. Draw the profile of a cam to give the motion as given below to a roller follower:

- a) Outward stroke of the follower during  $90^\circ$  of cam rotation,  
 b) Dwell for  $30^\circ$  of cam rotation,  
 c) Return stroke of the follower during  $100^\circ$  of cam rotation,  
 d) Dwell for the remaining period of cam rotation.

Lift of the follower is 25 mm ; Diameter of roller is 20 mm ; Minimum radius of the cam is 30 mm ; Line of stroke of the follower coincides with the axis of cam. The outward stroke takes place with uniform velocity, and the return stroke with uniform and equal acceleration and retardation. [10]

OR

9. The follower of a tangent cam is operated through a roller of 24 mm diameter, and its line of stroke passes through the axis of the cam. The minimum radius of the cam is 40 mm, nose radius is 12mm, and the lift is 25 mm. If the speed of rotation of the cam is 900 rpm, find the velocity of the follower at the instant when the cam is  $20^\circ$  from the full lift position. [10]

AG AG AG AG AG AG AG /

10.a) State and prove the law of gearing.

b) In a sun and planet gear train, the sun gear having 60 teeth is fixed to the frame. Find the number of teeth on the planet wheels and the annular wheel, if the annulus rotates 130 times in the same time when the arm rotates 100 times, both in the same direction. [5+5]

AG AG AG AG AG AG AG /

OR

11.a) A rack is being driven by an 18-teeth pinion of involute profile and 120 mm pitch circle diameter. The addendum of both pinion and rack is 6 mm. Find the least pressure angle required to avoid interference.

b) Prove that the velocity of sliding is proportional to the distance of the point of contact from the pitch point. [5+5]

AG AG AG AG AG AG AG /

---ooOoo---

AG AG AG AG AG AG AG /

AG AG AG AG AG AG AG /

AG AG AG AG AG AG AG /

AG AG AG AG AG AG AG /

AG AG AG AG AG AG AG /