

Code No: 134AM

R16

JAWAHARLAL NEHRU TECHNOLOGICAL UNIVERSITY HYDERABAD

B.Tech II Year II Semester Examinations, April - 2018

CONTROL SYSTEMS

(Common to EEE, ECE, EIE)

Time: 3 Hours

Max. Marks: 75

Note: This question paper contains two parts A and B.

Part A is compulsory which carries 25 marks. Answer all questions in Part A.

Part B consists of 5 Units. Answer any one full question from each unit.

Each question carries 10 marks and may have a, b, c as sub questions.

PART- A

(25 Marks)

- 1.a) Write the Manson's gain formula.
- b) What are the basic properties of SFG?
- c) What are the standard test signals used in control systems?
- d) Distinguish between type and order of a system.
- e) Define a stable system.
- f) Explain the basics of root locus plot.
- g) What is polar plot?
- h) Define gain and phase margins.
- i) What is state diagram?
- j) Mention any four advantages of state variable representation.

[2]
[3]
[2]
[3]
[2]
[3]
[2]
[3]
[2]
[3]

PART-B

(50 Marks)

- 2.a) Compare the AC and DC servomotors.

- b) For the system represented by the block diagram shown in figure 1. Find $\frac{C}{R}$.

[4+6]

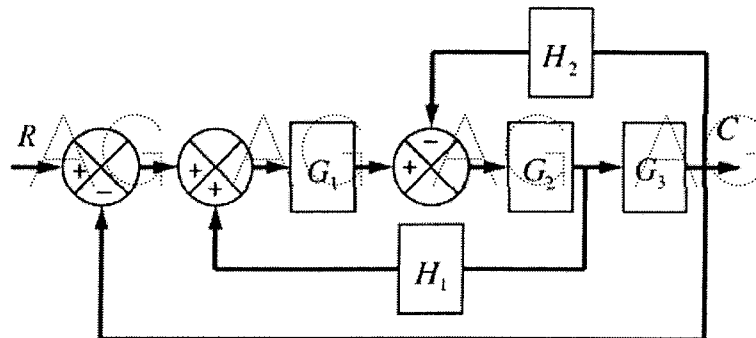

Figure: 1

OR

3.a) What are the characteristics of servomotors?

b) Find the overall gain $\frac{C(s)}{R(s)}$ for the signal flow graph shown in figure 2. [4+6]

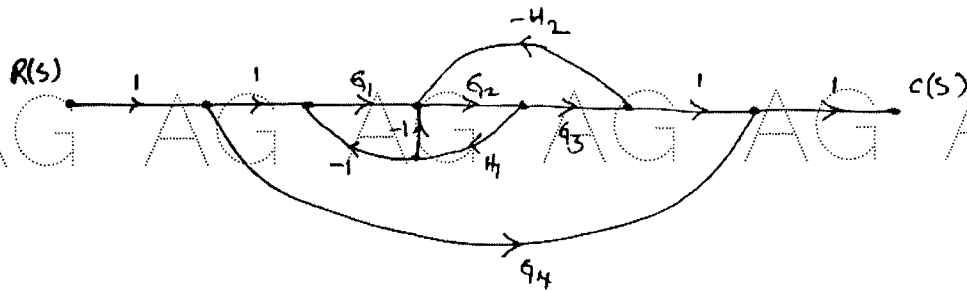

Figure: 2

4. The open-loop transfer function of a unity feedback control system is given by $G(s) = \frac{9}{s(s+3)}$. Find the natural frequency of response, damping ratio, damped frequency and time constant. [10]

OR

5. For unity feedback control system the open loop transfer function, $G(s) = \frac{10(s+2)}{s^2(s+4)}$. Find the e_{ss} when the input is $r(t) = 3 - 2t + 3t^2$. And find $K_p, K_v,$ and K_a . [10]

6.a) Determine the RH stability of given characteristic equation, $s^4 + 8s^3 + 18s^2 + 16s + 5 = 0$.

b) Sketch the root locus of the system, whose open loop transfer function is,

$$G(s) = \frac{K(s+15)}{s(s+1)(s+5)} \quad [4+6]$$

OR

7. Given $G(s) = \frac{Ke^{-0.2s}}{s(s+2)(s+8)}$. Find K so that the system is stable with, a) $GM=2\text{db}$, b) $PM=45^\circ$ [10]

8. The open loop transfer function is given by $G(s)H(s) = \frac{K(1+4s)}{s^2(1+s)(1+2s)}$, Determine the stability of closed loop system. [10]

OR

9. The open-loop transfer function of a system is given by

$$G_p(s) = \frac{K}{s(1+0.1s)(1+0.2s)}$$

Design a lag-lead compensator to meet the $K_v=100\text{sec}^{-1}$ and Phase margin $\geq 30^\circ$. [10]

AG AG AG AG AG AG AG A

10.a) Define: i) State ii) State variables iii) State space representation.

b) Find the state transition matrix for the following matrix, $A = \begin{bmatrix} 1 & 0 \\ -1 & 1 \end{bmatrix}$.

c) Obtain the state space representation for the following differential equation.
 $\ddot{y} + 5\dot{y} + 7y = 114$

Where 'y' is the output and 'u' is the input.

AG AG AG AG AG AG AG A

11. The state equation of a linear-time invariant system is given as,

$$\dot{X} = \begin{bmatrix} 0 & 5 \\ -1 & -2 \end{bmatrix} X + \begin{bmatrix} 1 \\ 1 \end{bmatrix} r \text{ and } y = [1 \quad 1] X,$$

Find the transfer function and draw the state diagram.

[10]

AG AG AG AG AG AG AG A

---ooOoo---

(

AG AG AG AG AG AG AG A

AG AG AG AG AG AG AG A

(

AG AG AG AG AG AG AG A

AG AG AG AG AG AG AG A

AG AG AG AG AG AG AG A