

R18

Code No: 153AP

JAWAHARLAL NEHRU TECHNOLOGICAL UNIVERSITY HYDERABAD

B. Tech II Year I Semester Examinations, March - 2022

ELECTRICAL CIRCUIT ANALYSIS  
(Electrical and Electronics Engineering)

Time: 3 Hours

Max. Marks: 75

Answer any five questions  
All questions carry equal marks

---

- 1.a) State and explain superposition theorem.  
b) Using mesh analysis, find the current 'I' in the circuit shown in figure 1. [7+8]

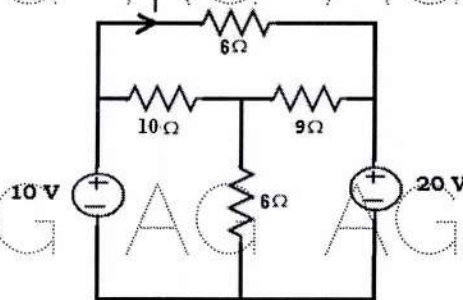

Figure: 1

- 2.a) State and explain maximum power transfer theorem.  
b) Using Thevenin's theorem, find the current in 10Ω resistor in the circuit shown in figure 2. [7+8]

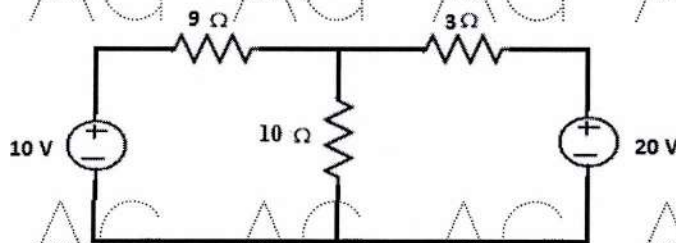

Figure: 2

- 3.a) Derive the expression for the transient current in series RL circuit with AC excitation.  
b) Find the expression for the current  $i(t)$  in the circuit shown in figure 3. The initial voltage across the capacitor is 10 V and the initial current in the inductor is 5A. [8+7]

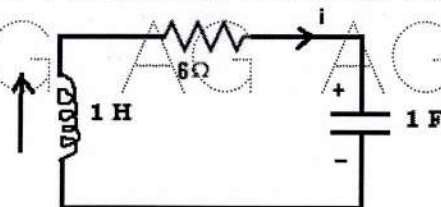

Figure: 3

- 4.a) Derive the expression for the transient current in series RLC circuit with DC excitation.  
 b) In the circuit shown in figure 4, determine the current in the inductor for  $t > 0$ . The switch is closed at  $t = 0$ . [8+7]

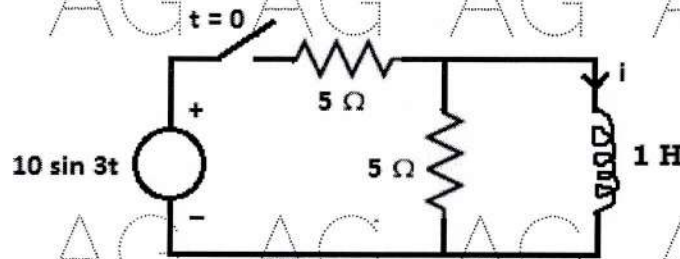

Figure: 4

- 5.a) Draw the phasor diagram of series RL circuit with sinusoidal excitation. Explain the relationship between different phasors.  
 b) Determine RMS and Average values of the waveform shown in figure 5. [8+7]

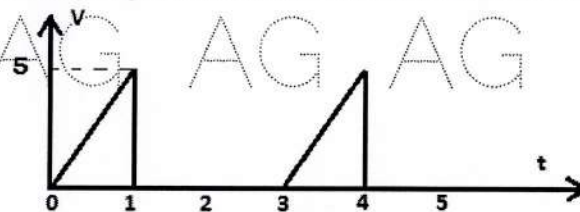

Figure: 5

- 6.a) Draw the phasor diagram of series RLC circuit with sinusoidal excitation. Explain the relationship between different phasors.  
 b) A balanced delta connected load draws 10 kW at a power factor of 0.8 lagging. If the three phase system has a line voltage of 400V, find the impedance of each phase and the total complex power of the load. [8+7]
- 7.a) Discuss in detail about the transfer function representation.  
 b) A series combination of resistance of  $200\Omega$  and a coil with inductance 1 H and winding resistance  $10\Omega$  and a capacitor of  $0.5\ \mu\text{F}$  is connected to an AC supply with internal resistance  $5\ \Omega$ . Find the resonant frequency, quality factor, lower and upper cut off frequencies. [6+9]

- 8.a) What are hybrid parameters? How to calculate them?  
 b) For the circuit shown in figure 6, determine impedance parameters. [7+8]

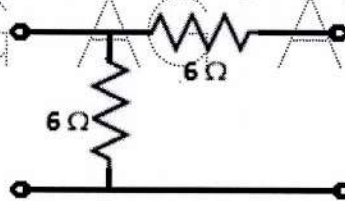

Figure: 6