

R18

Code No: 154BF

JAWAHARLAL NEHRU TECHNOLOGICAL UNIVERSITY HYDERABAD

B. Tech II Year II Semester Examinations, February/March - 2022

KINEMATICS OF MACHINERY

(Common to ME, MCT)

Time: 3 Hours

Max. Marks: 75

Answer any five questions
All questions carry equal marks

1. Explain various classes of kinematic pairs quoting with examples. [15]
2. What are various inversions of a double slider crank mechanism? Explain any two of them. [15]
3. The mechanism of a wrapping machine as shown in figure 1 has the following dimensions O_1A is 100 mm, AC is 700mm, BC is 200mm, O_3C is 200mm, O_2E is 400mm, O_2D is 200mm and BD is 150mm. The crank O_1A rotates at a uniform speed of 100 rad/s. Find the velocity of the point E of the bell crank lever by instantaneous centre method. [15]

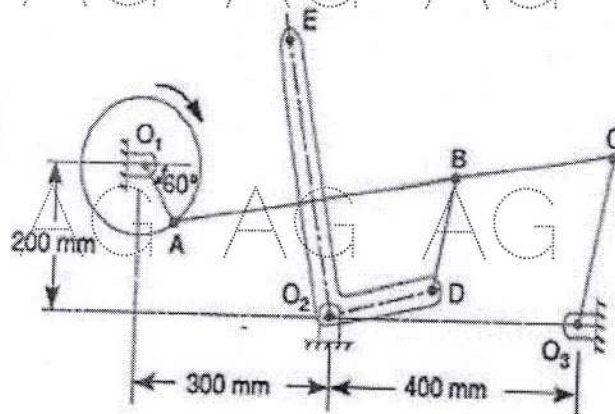

Figure: 1

4. Figure 2 shows a six link mechanism. The dimensions of the links are $OA=220$ mm, $AB=485$ mm, $BQ=310$ mm, $BC=590$ mm and $CD=400$ mm. For the position when the crank OA makes an angle of 60° with vertical, find the velocity of the slider D . The crank OA rotates clockwise at 150rpm. [15]

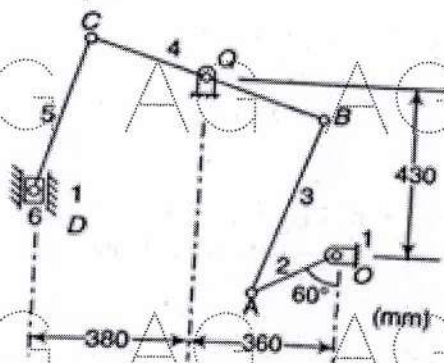

Figure: 2

AG AG AG AG AG AG AG A

5.a) Explain and prove that the Peaucellier mechanism is used for generating exact straight line motion.

b) Derive the condition for correct steering and explain in detail. [8+7]

AG AG AG AG AG AG AG AG A

6.a) Distinguish between the Davis and Ackerman's steering gear mechanisms and explain.

b) Derive an expression for the ratio of angular velocities of the shafts of a Hooke's joint. [8+7]

7. A cam, with a minimum radius of 25 mm, rotating clockwise with simple harmonic motion is to be designed to give a roller follower, at the end of a valve rod, motion described below : a) To raise the valve through 50 mm during 120° rotation of the cam; b) To keep the valve fully raised through next 30° ; c) To lower the valve during next 60° ; and d) To keep the valve closed during rest of the revolution i.e. 150° ; The diameter of the roller is 20. Draw the profile of the cam when the line of stroke of the valve rod passes through the axis of the cam shaft. [15]

AG AG AG AG AG AG AG A

8. The number of teeth on the gear and the pinion of two spur gears in mesh are 30 and 18 respectively. Both the gears have a module of 6 mm and a pressure angle of 20° . If the pinion rotates at 400 rpm, what will be the sliding velocity at the moment the tip of the tooth of pinion has contact with the gear flank? Take addendum equal to one module. Also, find the maximum velocity of sliding. [15]

AG AG AG AG AG AG AG A

---ooOoo---

AG AG AG AG AG AG AG A

AG AG AG AG AG AG AG A

AG AG AG AG AG AG AG A

AG AG AG AG AG AG AG A